



**HeliFlow™
Low Pulse,
Twisted Lobe™
Blowers/
Vacuum Pumps**



Introducing the Gardner Denver® HeliFlow™ – Low Pulse, Twisted Lobe Positive Displacement Blowers/Vacuum Pumps for lower noise efficiency and greater performance in a variety of applications.

BUILT BY THE INDUSTRY LEADERS IN POSITIVE DISPLACEMENT BLOWER TECHNOLOGY

Recognized for over 50 years for design innovation and manufacturing technology, Gardner Denver continues their leading edge reputation with the introduction of the HeliFlow low pulse, twisted lobe positive displacement blowers/vacuum pumps. Incorporating proven positive displacement design and manufacturing techniques into new twisted lobe technology, Gardner Denver has created a new low noise solution to the many applications for positive displacement blowers and vacuum pumps.

REVOLUTIONARY TWISTED LOBE, LOW PULSE, LOW NOISE DESIGN

HeliFlow's innovative twisted lobe impeller design results in lower pulse, lower vibration operation characteristics while providing slightly higher pressure and flow performance as compared to other similar size units. As a result, users can expect quieter performance with the added assurance that optimum pressure and flow performance is always at hand. Noise silencers often needed for traditional positive displacement blowers/vacuum pumps may not be necessary to achieve desired minimal noise levels.

INTEGRATING PROVEN PLATFORM AND INNOVATIVE DESIGN

While the rotor technology is new, many of the HeliFlow features are proven designs as a result of Gardner Denver's many years of positive displacement engineering experience. Features such as hardened high-strength gears that are press fit and secured with shaft pins for continuous accurate gear alignment, and our one-piece case for superior structural integrity and minimal torsional twist. Each model features highly reliable splash oil lubrication at both the gear end and the shaft end of the pump for longer life and reduced service intervals.

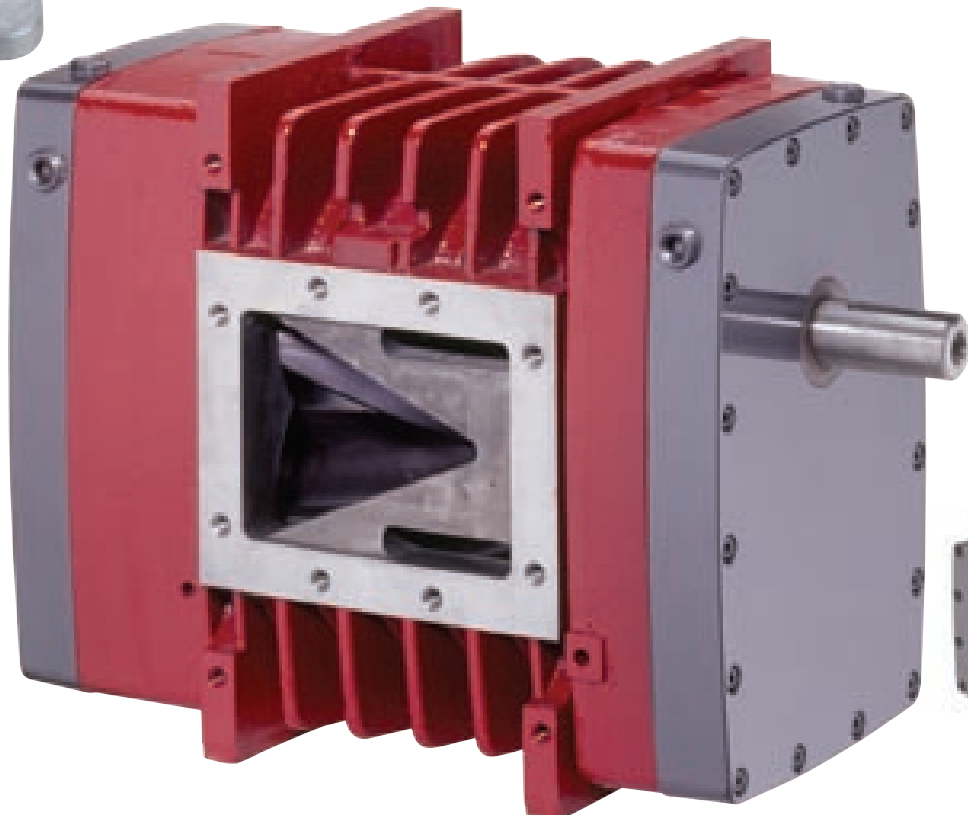

- **Advanced Design Features**
- **Proven Performance and Reliability**
- **Backed by Local Professional Sales and Service Network**



Horizontal, No Flange

Discharge Pulsation Comparison

LOWER NOISE

Discharge pulsation is the chief contributor to high noise levels. HeliFlow provides the lowest pressure pulse.

GREATER ACCURACY AND CONTROL

Capacity changes from the blower result in lower accuracy and poor control from downstream instrumentation. HeliFlow provides the lowest flow variation.

HIGHER RELIABILITY

Discharge pressure pulsation causes axial thrust and higher variations in torque resulting in reduced bearing life and reduced life of downstream valves and instrumentation. HeliFlow's smooth pulse operation extends the life of these components.

HeliFlow Low Pulse, Twisted Lobe Blower

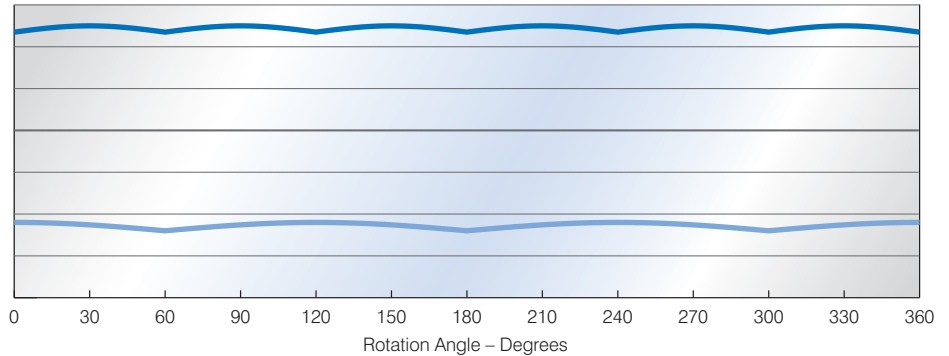

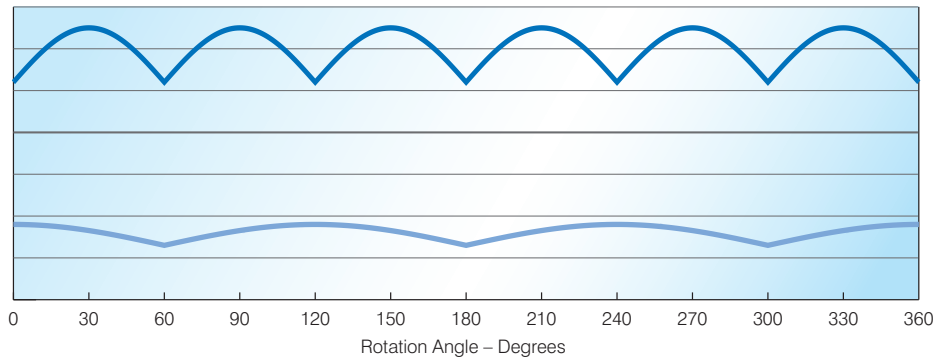

Typical Trilobe Blower

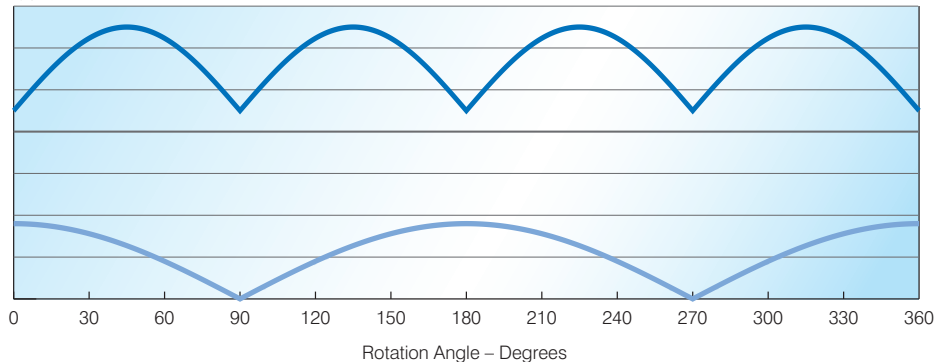

Typical Dual Lobe Blower



 Change in Torque
 Change in Flow

FLEXIBLE DESIGN FOR EASY INSTALLATION

The HeliFlow is designed for easy installation featuring unique integral mounting bosses that are precision machined for ease of installation and drive system

alignment. Independent oil sumps allow HeliFlow to be mounted vertically or horizontally. Oil site glass can easily be configured according to the mounting position.

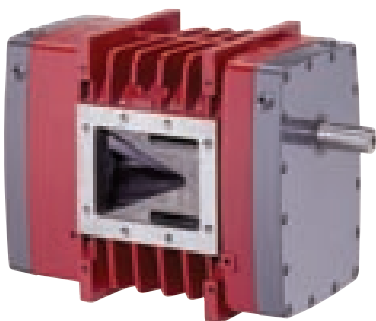

Vertical, No Flange



Horizontal, Short Flange

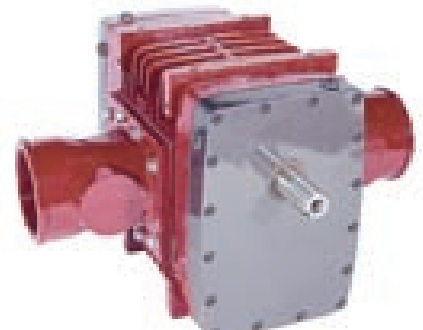

Vertical, Long Flange

Performance Advantage Through Advanced Design

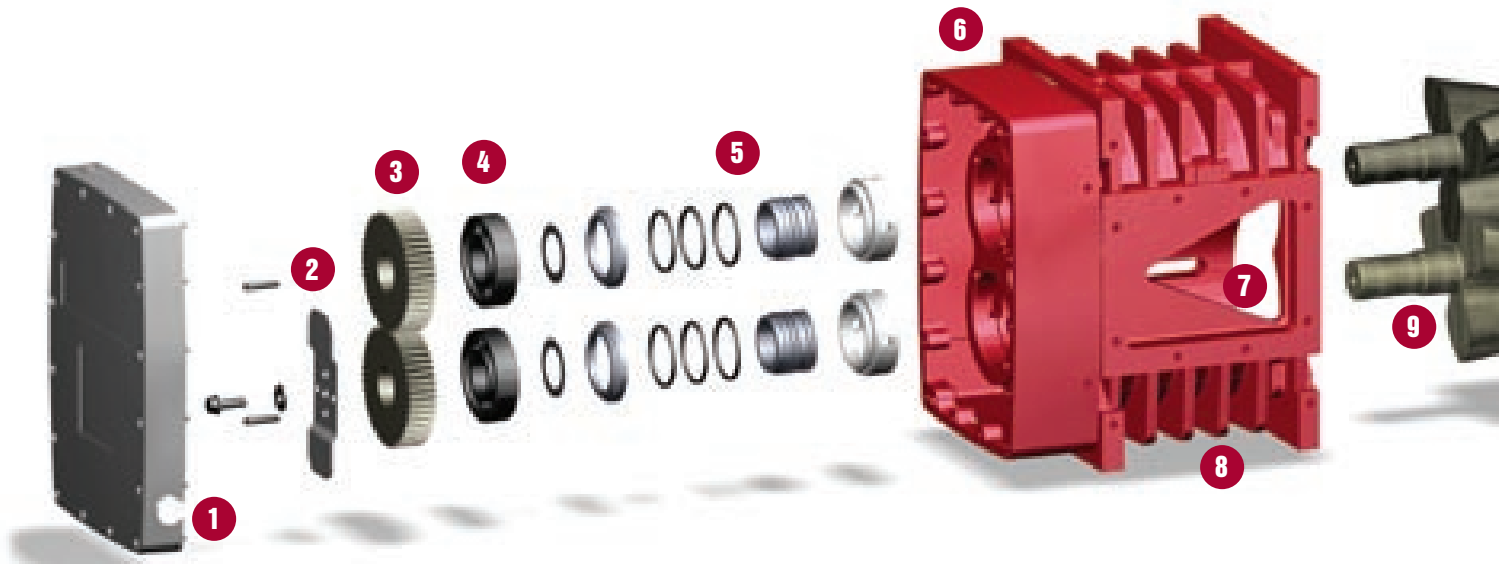

- 1** Full view oil sight glasses are standard and strategically located for ease of inspection.
- 2** Reliable splash oil lubrication at both gear and drive ends provide superior gear and bearing lubrication for longer life at all operating conditions with minimal maintenance.
- 3** Each timing gear is precision machined from alloy steel forgings and pinned to the shaft to prevent timing slip under the most severe operating conditions.
- 4** Oversized, precision fit bearings mounted on large diameter shafts provide longer blower service life and added overhung load capacity.
- 5** Advanced oil and air seal design incorporates piston rings and flinger for maximum seal life in continuous, severe duty applications to provide leak-free operation.
- 6** The integral cylinder and gear-side head plate incorporate large external fins for greater strength and heat dissipation to prevent distortion that can affect internal clearances and reduce performance.
- 7** The unique triangular tuned ports and extra cylinder mass aid in reducing noise levels.
- 8** Machined mounting bosses allow ease of blower installation in vertical or horizontal configuration into any new or existing system.
- 9** Rotors and shafts are machined from a single, high-strength ductile iron casting and dynamically balanced to handle continuous maximum loads without fatigue, deflection or vibration.

HELIFLOW PRESSURE PERFORMANCE DATA

MODEL	RPM	PRESSURE									
		5 PSIG		7 PSIG		10 PSIG		12 PSIG		15 PSIG	
		CFM	BHP	CFM	BHP	CFM	BHP	CFM	BHP	CFM	BHP
HF 406	1760	152	4.7	142	6.5	130	9.2	122	11.0	113	13.7
	2190	202	6.0	192	8.2	180	11.5	173	13.8	163	17.1
	2620	253	7.4	243	10.0	230	14.1	223	16.7	213	20.7
	3600	367	11.1	357	14.7	345	20.2	338	23.9	328	29.4
	4000	414	12.8	404	16.8	392	23.0	385	27.0	375	33.2
HF 408	1760	224	6.8	211	9.4	193	13.3	183	15.9	-	-
	2190	297	8.5	284	11.8	266	16.6	256	19.9	-	-
	2620	371	10.4	357	14.3	339	20.1	329	24.0	-	-
	3600	537	15.2	523	20.6	506	28.6	496	33.9	-	-
	4000	605	17.4	591	23.3	574	32.2	564	38.2	-	-

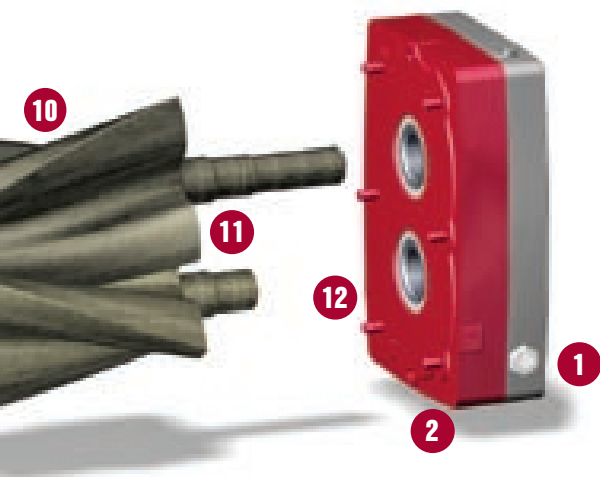

Innovation to Serve Every Industrial Application

- 10** Innovative smooth running rotor profile, precision machined with advanced CNC milling technology significantly reduces pulsations and discharge noise levels for quieter operation.
- 11** Solid rotor design eliminates the potential for vibration caused when hollow rotors become unbalanced due to build-up of ingested material inside the rotor cavities.
- 12** Heavy wall and internal ribbed head plate casting is ground on the interior surface to precise tolerances and bearing fits are machined to assure exact bearing positioning.

<i>Industry</i>	<i>Application</i>
Aquaculture	■ Aeration
Cement and Lime	■ Fluidization and Conveying
Chemical	■ Vacuum Processing and Conveying
Dairy	■ Automated Milking
Dry Bulk Hauling	■ Trailer Unloading and Fluidization
Environmental Services	■ Sewer and Valve Box Cleaning
Industrial	■ Material Vacuuming
Milling and Baking	■ Blending and Conveying
Power Generation	■ Fly Ash Conveying and Combustion Air
Pulp and Paper	■ Chip Conveying and Process Vacuum
Resin and Plastic	■ Processing and Conveying
Vacuum Excavation	■ Potholing and Slurry Recovery
Wastewater	■ Aeration and Backwashing

HELIFLOW VACUUM PERFORMANCE DATA

MODEL	RPM	VACUUM							
		10 "Hg		12 "Hg		14 "Hg		16 "Hg	
		CFM	BHP	CFM	BHP	CFM	BHP	CFM	BHP
HF 406	1760	140	4.6	130	5.5	119	6.4	–	–
	2190	191	5.9	181	7.0	170	8.1	–	–
	2620	241	7.3	231	8.6	220	9.9	–	–
	3600	356	10.9	346	12.7	335	14.5	322	16.3
	4000	403	12.6	392	14.6	381	16.6	369	18.6
HF 408	1760	208	6.7	194	7.9	179	9.2	–	–
	2190	281	8.4	267	10.0	252	11.6	–	–
	2620	354	10.2	340	12.1	325	14.0	–	–
	3600	521	15.0	507	17.6	492	20.2	474	22.9
	4000	589	17.1	575	20.1	560	23.0	542	25.9



Genuine GD Parts and Lubricants

You can keep your Gardner Denver HeliFlow investment running smoothly for years with Genuine Gardner Denver parts and lubricants from your local Authorized Gardner Denver Sales and Service Representative. These professionals provide you the expert guidance you appreciate for sales assistance, installation support and maintenance advice. Whether you're replacing a typical wear component or changing the grease or oil, nothing outperforms genuine Gardner Denver factory parts and lubricants. They're specifically engineered for superior performance and extended life of your blower/vacuum pump.

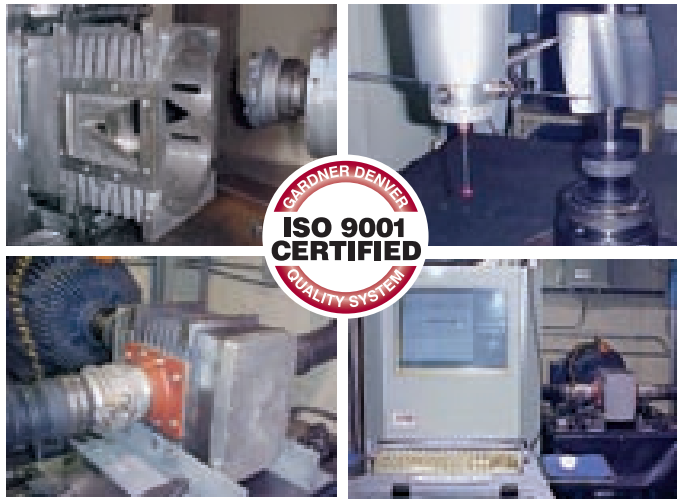

Advanced Engineering, World Class Manufacturing and Superior Service

The HeliFlow low pulse, twisted lobe blower/vacuum pump is the result of Gardner Denver's innovative engineering capability and blower design expertise. Every HeliFlow is machined, assembled, tested, quality checked and packaged in our state-of-the-art 330,000 sq. ft. ISO 9001 Certified facility in Sedalia, Missouri. The superior and consistent quality found in each HeliFlow is the result of a significant investment in people, advanced Flexible Machining Systems (FMS) and numerous quality inspections throughout the manufacturing process. This quality assurance is backed by one of the largest and most experienced Distributor Networks in the industry providing a wide range of sales and service support.

DIMENSIONAL DATA

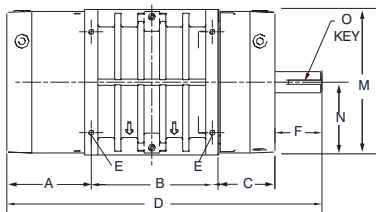

HORIZONTAL CONFIGURATION

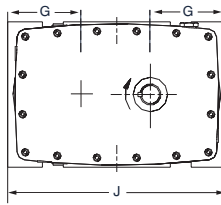

VERTICAL CONFIGURATION

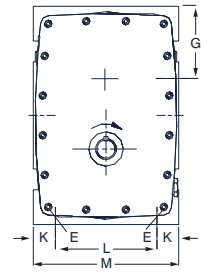
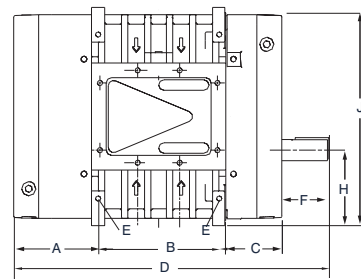

Model	Weight	Shaft Diameter	A	B	C	D	E	F	G	H	J	K	L	M	N	O
HF 406	146 lbs.	1.25	5	4.7	4.2	13.5	3/8-16 UNC	2.8	4.5	6.5	13	1.33	6	8.66	4.33	0.25x0.25x2.0
HF 408	173 lbs.	1.25	5	7.2	4.2	16.0	3/8-16 UNC	2.8	4.5	6.5	13	1.33	6	8.66	4.33	0.25x0.25x2.0

All dimensions shown in inches. Dimensions for installation purposes provided upon request.

Contact Your HeliFlow

For additional information, contact your local representative or

Gardner Denver Blower Division

100 Gardner Park, Peachtree City, GA 30269

Toll Free 800-543-7736

Phone 770-632-5000 • Fax 770-486-5629

E-mail: blowersmktg@gardnerdenver.com

Visit our web site: www.gardnerdenver.com



For Parts Information, Contact:

Gardner Denver Blower Division Customer Service

Phone 770-632-5000 • Fax 770-486-5629